

CAMBRIDGE

MODEL CSW-10AT-CS CRANE SCALE SERIES



Applications:

- Shipping & Receiving
- General Purpose Weighing
- Work - In Process
- Anywhere an overhead crane is used and weight readings are desired.

Standard Features Include:

- Cast Aluminum Enclosure
- AC/Battery Operation - 20 hrs. between charges
Includes Battery with Internal Battery Charger and External Wall Battery Charger
- Selectable Sleep Mode to Conserve Battery Power
- Weight Totalization
- Net / Gross Display Modes
- Full Range Auto Tare
- Adjustable Sample Rate
- Digital Filtering
- All Pushbutton Controls
- .56" LED Display with Selectable Brightness
- On / Off Switch
- Center of Zero Annunciator
- Lb / Kg Conversion
- Span Adjustment at Increasing or Decreasing Weights
- 1 to 5 Points of Digital Calibration
- Full Range Push Button Zero
- Auto Zero Tracking
- Adjustable Motion Detection
- 150% Safe Overload of Load Cell
- 300% Ultimate Overload of Load Cell
- Light Weight for Easy Handling and Transport.
10 - 20 lbs depending on capacity. See back page for optional ultra-tough carrying case.
- Keypad Calibration with Audit Trail

Approvals:



COC # 11-073



MADE IN THE USA



Spring loaded latch on battery compartment allows quick and easy access to the battery. The Model CSW-10AT-CS Crane Scale includes battery, internal battery charger with AC adapter/cable and external wall mount charger for continuous A/C or battery operation.

**Cambridge Scale Works, Inc. • P O Box 670 • Honey Brook, PA 19344
(800) 292-7640 • (610) 273-7040 • www.cambridgescale.com**

CAMBRIDGE

MODEL CSW-10AT-CS CRANE SCALE SERIES

Model Number	Capacity & Graduation	Standard Eye & Hook	Approx. Ship Weight
CSW-10AT-CS-500	500 lbs. X .1 lbs.	1/2-20 Eye / 1.5 Ton Hook	10 lbs.
CSW-10AT-CS-1K	1,000 lbs. X .2 lbs.	1/2-20 Eye / 1.5 Ton Hook	10 lbs.
CSW-10AT-CS-2K	2,000 lbs. X .5 lbs.	1/2-20 Eye / 1.5 Ton Hook	10 lbs.
CSW-10AT-CS-5K	5,000 lbs. X 1 lb.	3/4-16 Eye / 5 Ton Hook	18 lbs.
CSW-10AT-CS-10K	10,000 lbs. X 2 lbs.	3/4-16 Eye / 5 Ton Hook	20 lbs.

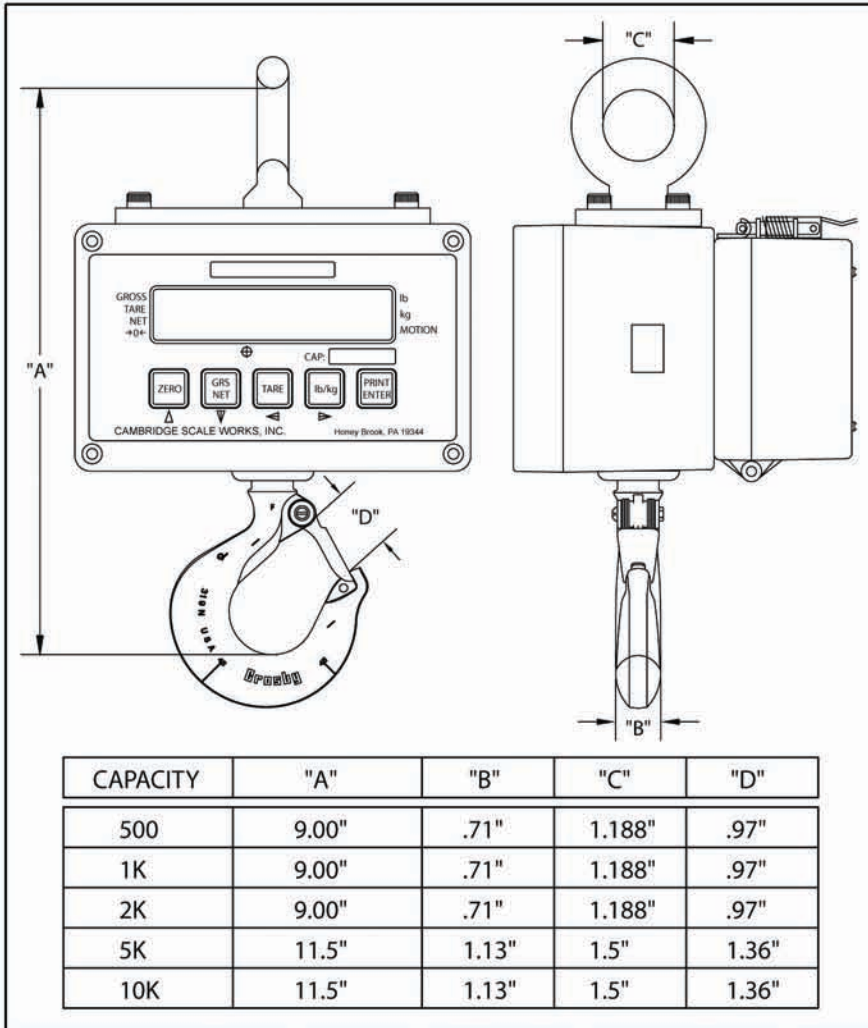

Dimensions subject to change without notice. Consult factory for all space restricted applications.

Distributed By:

Includes battery, internal battery charger with AC adapter/cable and external wall mount charger for continuous A/C or battery operation.



Options:

- Rugged Storage-Carrying Case
- Spare Battery



Optional Rugged Storage-Carrying Case shown with optional Spare Battery

Cambridge Scale Works, Inc. will warrant this product for one full year against defects in material and/or workmanship.

**Cambridge Scale Works, Inc. • P O Box 670 • Honey Brook, PA 19344
(800) 292-7640 • (610) 273-7040 • www.cambridgescale.com**