

C A M B R I D G E

SCALE WORKS INCORPORATED

MODEL: SSCSW-20AT

DIGITAL WEIGHT INDICATOR

INSTALLATION, SET-UP & OPERATION



COC # 06-070A1



MEASUREMENT CANADA
AM-5778C



Made in USA

Cambridge Scale Works. • P O Box 670 • Honey Brook, PA 19344
(800) 292-7640 • (610) 273-7040 • www.cambridgescale.com

MANUAL P/N 5999-1036-00 (2/14)

TABLE OF CONTENTS

Meter connections -----	3
1.0 Operation -----	4
1.1 Key Functions -----	4 - 5
1.2 Error Messages -----	6
2.0 Scale Procedure -----	7
2.1 Software Navigation Flowchart -----	7 - 8
2.2 Scale Menu Definitions -----	9 - 11
3.0 Calibration Procedure -----	12
3.1 Calibration Menu Definitions -----	12
3.2 Calibration -----	13
3.3 Linearity Correction -----	13
3.4 Quick Calibration -----	14
3.5 Quick Calibration Linearity correction -----	14
4.0 Communications Setup -----	15
4.1 Communications Menu Definitions -----	15 – 18
Table 4.1 Numeric Character Codes -----	19
Figure 4.1a Sample Header Footer Worksheet-----	20
Figure 4.1b Blank Header Footer Worksheet-----	21
Sample Tickets-----	22
5.0 Testing Procedure -----	23
5.1 Testing Menu Definitions -----	23
6.0 Troubleshooting -----	24-25
7.0 Warranty -----	26
8.0 Assistance -----	26

METER CONNECTIONS

To connect power to the **SSCSW-20 indicator**. First make sure the ON/Off switch on the rear of the meter is in the off position. Connect the power cable to a standard 110VAC wall outlet.



On/OFF
Switch

Power
Connection



SIGNAL

Pin #	Description
F	-SEN
E	+SEN
D	-SIG

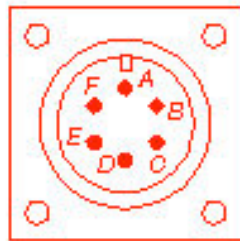

Pin #	Description
A	+EXC
B	-EXC
C	+SIG

1.0 OPERATION

1.1 Key Functions

Numeric Keys (0-9) Used to enter numeric values and choices.

ZERO Brings the scale to a zero balance reading. If the *ZERO* key is pressed and held for 5 seconds the Calibration zero value will be displayed.

GRS/NET Toggles the display between Gross weight and Net weight. This key is also used to enter Setup & Calibration Mode. To enter, press and hold this key until the Parameter (**P xxx**) and Calibration Event counters are displayed, then release. Immediately after *CodE* is displayed, enter in sequence *TARE*, *lb/kg*, *GRS/NET*, and *PRINT/ENTER*. The display will indicate *ScAlE*.

Note: **P xxx** and **C xxx** are event counters that will increment each time one or more changes are made to the Scale or Calibration Parameters.

TARE Enter Tare weights by applying a load to the scale, then press the tare key. A Tare weight may also be entered by using the numeric keys to enter a value, then press Tare.

Note: If *Ntep* or *Angle* is enabled the tare can only be keyed in when the displayed weight is in the zero band.

If *Non-Ntep* is enabled the Tare can be entered anytime.

To view the current Tare value, press and hold the *TARE* key for 3 second.

Clearing a Tare can be completed by 1.) Enter a 0 then press the Tare key or 2.) Press the zero key.

Lb/kg Toggles the display between pounds and kilograms.

PIECE COUNTING When adding piece weight, use the numeric keypad to enter the weight value (with a decimal place) then press *PIECE/COUNT*. When adding the number of pieces, use the numeric keypad to enter a whole number (with no decimal place) then press the *PIECE/COUNT* key. Pressing the *PIECE/COUNT* key will toggle between pieces and the average piece weight display.

1.1 Key Functions Continued:

PIECE COUNTING

Press *GRS/NET* to switch to weighing mode and *PIECE/COUNT* key to view the piece count.

Enter 0 and press *PIECE/COUNT* to clear the piece weight.

TOTAL

With a weight on the scale press the *TOTAL* key to totalize the weight.

Enter 0 and press the *TOTAL* key to display the current total.

When *TOTAL* is pressed while the displayed weight is in the zero band, the current total will be displayed, printed, and cleared.

ID

When the *ID* key is pressed, the last 6 digits of an ID number will be displayed. To clear an ID number press *ID* then while the current ID number is displayed press Zero.

To enter a new ID number, press the *ID* key and enter a value up to 20 digits then press *PRINT/ENTER*.

If a barcode scan is received on COM2 (02h, up to 20 ASCII characters, 0dh, 0ah) the alphanumeric value will be stored in the ID.

The ID No. will be cleared after the total is cleared or *ZERO* is pressed. ID No. will be printed just under the time and date.

If the ID No. is "0" this line will not be printed.

SET/POINT (Optional)

Press the *SET/POINT* key, then the up arrow to set the upper limit. Set hi will be displayed then "0" will be displayed. Using the numeric keypad, enter the desired value and press the *PRINT/ENTER* key.

Press the *SET/POINT* key, then the up arrow to set the lower limit. Set Lo will be displayed then "0" will be displayed. Using the numeric keypad, enter the desired value and press the *PRINT/ENTER* key.

Note: If "0" is entered for the upper or lower limit, the Setpoint option will be disabled.

1.2 Error Messages:

ScnEg	When the weight is more than 10 divisions negative from the zero calibration point.
OLD	The scale is in an overload condition.
BAtLo	Will flash when the battery voltage falls to 10.8VDC and will be displayed constantly when the voltage falls to 10.2VDC.
Err d	More than 5000 scale divisions have been selected in <i>SI</i> Nstep or <i>SI</i> Angle mode. More than 20,000 scale divisions have been selected in <i>SI</i> No Mode.
-----	Displayed when an entry was not accepted.

2.0 SCALE PROCEDURE: 2.1 Software Navigation Flowchart

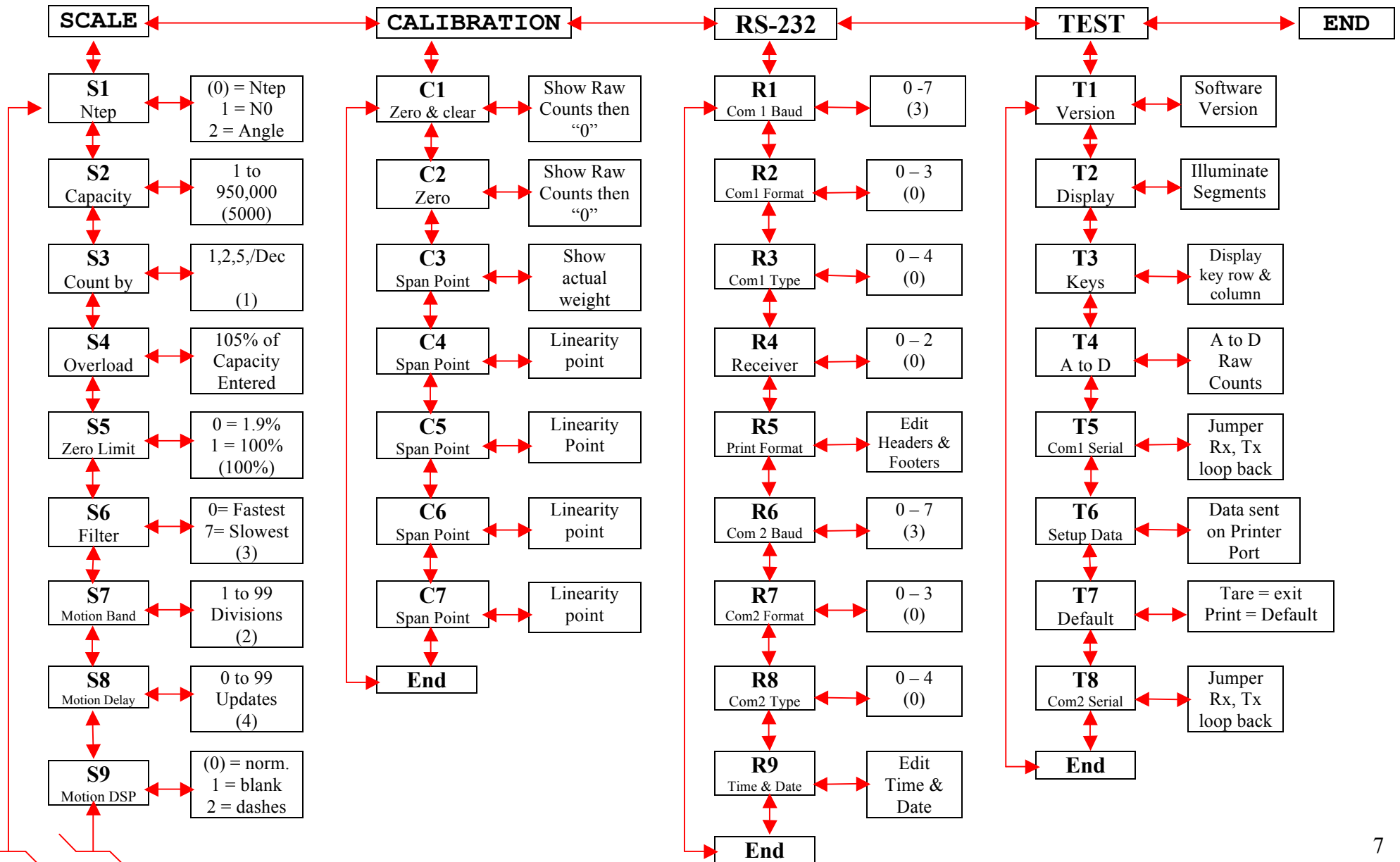

2.1 Software Navigation Flowchart



During setup you will be required to enter choices and numeric values. Enter These values using the numeric keys on the keypad. Next navigate the flowchart By using the keys described below.

ZERO ----- Key is used to move up.
 GRS/NET ----- Key is used to move down.
 lb/kg ----- Key is used to move right.
 TARE ----- Key is used to move left.
 PRINT/ENTER --- Key is used to enter data.

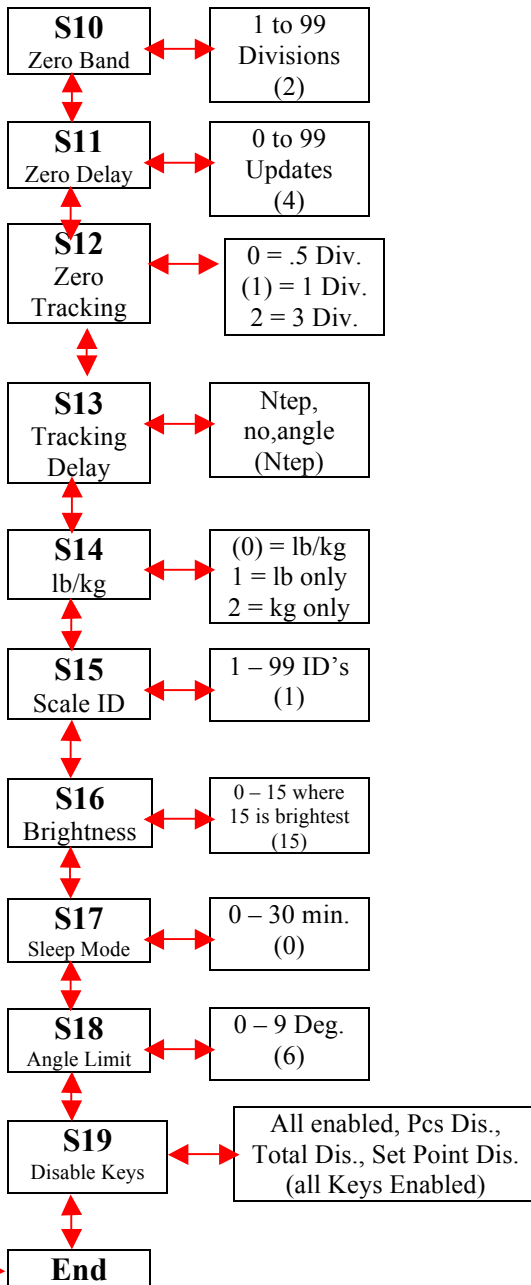

2.2 Scale Menu Definitions:

Enter Calibration / Setup mode by Pressing and holding the *GRS/NET* key until Parameter (*Pxxx*) and Calibration event counters are displayed. Immediately after *CodE* is displayed, enter in sequence *TARE*, *lb/kg*, *GRS/NET*, and *PRINT/ENTER*. *ScAIE* will be displayed. Press the down arrow key to enter the scale menu. Press the right arrow key to enter each sub menu.

-P xxx, C xxx are event counters that will increment each time one or more changes are made to the Scale or Calibration Parameters.

- S1 Ntep** **0** Non-Ntep mode 20,000 maximum division limit and no scale negative tests.
1 NTEP mode (Default)
2 Angle mode
Press the right arrow key to enter. Use the numeric keypad to enter the desired selection (0,1, or 2), then press the *PRINT/ENTER* key to save and exit. S1 will be displayed.
- S2 Capacity** 1 to 950,000 pounds. 5000 (Default)
Press the right arrow key to enter. Use the numeric keypad to enter the desired capacity, then press the *PRINT/ENTER* key to save and exit. S2 will be displayed.
- S3 Count By** .001, .01, .1, 1, .002, .02, .2, 2, .005, .05, .5, 5. 1(default)
Use the up and down arrow keys to choose the count by. Use the left and right arrow keys to choose the decimal place, then Press the *PRINT/ENTER* key to save and Exit. S3 will be displayed.
- S4 Overload** (105%) of the scale capacity.
Press the right arrow key to enter. Use the numeric keypad to enter the desired safe overload, then press the *PRINT/ENTER* key to save and exit. S4 will be displayed.
- S5 Zero Limit** **0** 1.9%
1 100% (Default)
Press the right arrow key to enter. Use the numeric keypad to enter the desired selection (0 or 1), then press the *PRINT/ENTER* key to save and exit. S5 will be displayed.
- S6 Filter** 0 to 7, Where 0 is the fastest response and least filtering and 7 is the slowest response or most filtering. 3 (Default)
Press the right arrow key to enter. Use the numeric keypad to enter the value, then Press the *PRINT/ENTER* key to Save and exit. S6 will be displayed.

2.2 Scale Menu Definitions Continued:

- S7 Motion Band** 1 to 99 divisions. The weight display must be stable within the selected number of divisions for the motion indicator to be turned off. 2 (Default)
Press the right arrow key to enter. Use the numeric keypad to enter the value, then press the *PRINT/ENTER* key to save and exit. S7 will be displayed.
- S8 Motion Delay** 0 to 99 updates. The weight display must be within the motion band for the selected number of updates in order to turn off the motion indicator. 4 (Default)
Press the right arrow key to enter. Use the numeric keypad to enter the value, then press the *PRINT/ENTER* key to save and exit. S7 will be displayed.
- S9 Motion Display**
- | | |
|----------|------------------|
| 0 | Normal (Default) |
| 1 | Blank |
| 2 | Dashes |
- Press the right arrow key to enter. Use the numeric keypad to enter the desired selection (0, 1, or 2), then press the *PRINT/ENTER* key to save and exit. S9 will be displayed.
- S10 Zero Band** 1 to 99 divisions. The weight display must return to zero within the selected number of divisions to be considered zero. 2 (Default) Press the right arrow key to enter. Use the numeric keypad to enter the value, then press the *PRINT/ENTER* key to save and exit. S10 will be displayed.
- S11 Zero Delay** 0 to 99 updates. The weight display must be within the zero band for the selected number of updates to be considered zero. 4 (Default) Press the right arrow key to enter. Use the numeric keypad to enter the value, then press the *PRINT/ENTER* key to save and exit. S11 will be displayed.
- S12 Zero Tracking**
- | | |
|----------|-----------------------|
| 0 | 0.5 divisions. |
| 1 | 1 division. (Default) |
| 2 | 3 division |
- Press the right arrow key to enter. Use the numeric keypad to enter the desired selection (0, 1, or 2), then press the *PRINT/ENTER* key to save and exit. S12 will be displayed.

2.2 Scale Menu Definitions Continued:

- S13 Tracking Delay** 0 to 99 updates. The amount of time that the display must be within the allowed graduations before it will automatically be zeroed. 0 (Default)
Press the right arrow key to enter. Use the numeric keypad to enter the value, then press the *PRINT/ENTER* key to save and exit. S13 will be displayed.
- S14 lb/kg** **0** lb/kg (Default)
1 lb only
2 kg only
Press the right arrow key to enter. Use the keypad to enter the selection (0, 1, or 2), then press the *PRINT/ENTER* key to save and exit. S14 will be displayed.
- S15 Scale ID** 1 to 99 Scale ID used in RF link output. 1 (Default)
Press the right arrow key and use the keypad to enter a value, then press the *PRINT/ENTER* key. S15 will be displayed.
- S16 Brightness** 0 to 15. Adjusts the LED display intensity where 15 is the brightest. 15 (Default)
Press the right arrow key to enter. Use the up and down arrow keys to increase or decrease the brightness, then press the *PRINT/ENTER* key to save and exit. S16 will be displayed.
- S17 Sleep Mode** 0 to 30 minutes. The display will turn off after the set time elapses with no scale activity. 0 (Default)
Press the right arrow key to enter. Use the numeric keypad to enter the value, then press the *PRINT/ENTER* key to save and exit. S17 will be displayed.
- S18 Angle Limit** 0 to 9 Degrees. 6 (Default)
Press the right arrow key and use the keypad to enter a value, then press the *PRINT/ENTER*. S18 will be displayed.
- S19 Disable Keys** **0** All keys enabled (Default)
1 Pieces disabled
2 Total disabled
3 Setpoint entry disabled (setpoint will still function).
4 Pieces, Total and Setpoint disabled.
5 All keys but *ZERO* and *PRINT/ENTER* will be disabled.
Press the right arrow key, and use the keypad to enter a selection (0, 1, 2, 3,4, or 5), then press the *PRINT/ENTER* key to save and exit. S19 will be displayed.

3.0 CALIBRATION PROCEDURE:

3.1 Calibration Menu Definitions:

- C1 Zero All** Raw counts, (Pitch and Roll if in angle mode) will be displayed. When *ZERO* is pressed an analog zero is done and all calibration span points will be cleared. If the indicator is in angle mode the Pitch and Roll offsets will also be Zeroed.
- C2 Zero** Zeroed raw counts, (Pitch and Roll if in angle mode) will be displayed. When *ZERO* is pressed an analog zero is done and all calibration span points will NOT be cleared. If the indicator is in angle mode the Pitch and Roll offsets will be Zeroed.
- C3 Span Point** The last Calibration weight will be displayed then the actual weight on the scale will be displayed. *If you do not wish to change the span point, press the TARE key to exit without making any changes.* If the displayed weight does not match the known test weight, use the numeric keypad to enter the correct weight. Press the *PRINT/ENTER* key to save and exit. The display will return to C3.
- C4-C7 Span Points** C4 to C7 are for linearity correction. They can be used in order and in any quantity or not at all if no correction is necessary. C4 to C7 may be entered at any time without effecting the original calibration points. The last calibration weight will be displayed then the actual weight on the scale will be displayed. If no calibration weight has been entered at this span point “*notset*” will be displayed then the actual weight on the scale is displayed. If the displayed weight does not match the known test weight, follow the steps described for C3 Span Point on adjusting the weight and entering the value.

3.2 Calibration:

Press and hold the *GRS/NET* key as described previously in section 2.2. *ScAIE* will be displayed. Press the *lb/kg* key to move right until CalIb is displayed. Press the *GRS/NET* key to move down, *C1* will be displayed. Press the *lb/kg* key to move right, the raw counts will be displayed. With no weight on the scale and the scale level, press the *ZERO* key, “0” will be displayed. Press the *PRINT/ENTER* key to save the entry. “0” is now entered and the display will return to *C1*.

Note: With the scale completely level use *C1* or *C2* to zero the angles. There is no need to use both *C1* and *C2*.

Press the *GRS/NET* key to move down until *C3* is displayed. Press the *lb/kg* key to enter. The last calibrated weight will flash then the current weight on the scale is displayed. Place a known test weight on the scale, with the scale level. Using the numeric keypad, enter the actual weight and press the *PRINT/ENTER* key to save and exit. The display will return to *C3*.

3.3 Linearity Correction

If Linearity Correction is needed, Press the *GRS/NET* key (from the Calibration menu) to move down until *C4* is displayed. Press the *lb/kg* key to move right, the last calibrated weight will flash or “*notset*” will flash if this point has not been previously set. Next the current weight on the scale will be displayed. Place a different known test weight (not the same test weight that was used for *C3*) on the scale. Using the numeric keypad, enter the actual weight and press the *PRINT/ENTER* key to save and exit. The display will return to *C4*. Repeat these steps for *C5*, *C6* and *C7*.

Linearity Correction points (*C4-C7*) can be used in any order and in any quantity or not at all if no correction is necessary. After calibration is complete you may return to these correction points and make changes to its value without affecting any of the original calibration points.

3.4 Quick Calibration

- I. With no weight on the scale.
 - A. Enter Setup / Calibration mode as described previously in the beginning of section 2.2. “*Scale*” will be displayed.
 - B. Press the *lb/kg* key. “*CALibr*” will be displayed.
 - C. Press the *GRS/NET* key until “*C2*” is displayed.
 - D. Press the *lb/kg* key to enter *C2*. The zero Calibration number will be displayed.
 - E. Press the *ZERO* key. “0” will be displayed.
 - F. Press the *PRINT/ENTER* key to enter the new zero calibration. “*C2*” will be displayed.
 - G. Press the *GRS/NET* key. “*C3*” will be displayed.
 - H. Press the *lb/kg* key to enter *C3*. The last span weight will flash, then the current weight on the scale will be displayed.
- II. Place a known weight, as close to the capacity as possible, on the scale.
 - A. Using the numeric keypad enter the correct value for the known weight.
 - B. Press the *PRINT/ENTER* key to enter the new calibration. “*C3*” will be displayed.
 - C. Press the *TARE* key. “End?” will be displayed.
 - D. Press the *PRINT/ENTER* key to exit Setup / Calibration mode.

3.5 Quick Calibration Linearity Correction

- I. With no weight on the scale.
 - A. Enter Setup / Calibration mode as described previously in the beginning of section 2.2. “*Scale*” will be displayed.
 - B. Press the *lb/kg* key. “*CALibr*” will be displayed.
 - C. Press the *GRS/NET* key until *C4* is displayed.
 - D. Press the *lb/kg* key to enter *C4*. “*nOtset*” or the last calibrated weight will flash, then the current weight on the scale will be displayed.
- II. Place a known weight on the scale.
 - A. Using the numeric keypad enter the correct value for the known weight.
 - B. Press the *PRINT/ENTER* key to enter the new calibrated linearity correction point. “*C3*” will be displayed.
 - C. Press the *TARE* key. “End?” will be displayed
 - D. Press the *PRINT/ENTER* key to exit Setup / Calibration mode.

If additional Linearity correction points are desired, Follow the steps above for *C5*, *C6*, and/or *C7*.

4.0 COMMUNICATIONS SETUP

4.1 Communications Menu Definitions:

R1	Baud Rate	0	1200
		1	2400
		2	4800
		3	9600 (Default)
		4	19200
		5	38400
		6	57600
		7	115200

Press the right arrow key to enter. Use the numeric keypad to enter the desired selection (0 - 7), then press the *PRINT/ENTER* key to save and exit. R1 will be displayed.

R2	Output Format	0	Gross, Tare, Net (Default)
		1	Weight only
		2	Net only
		3	Gross only

Press the right arrow key to enter. Use the numeric keypad to enter the desired selection (0 - 3), then press the *PRINT/ENTER* key to save and exit. R2 will be displayed.

R3	Output Type	0	Output on command. Standard Print. (Default) Output as selected by R2 Output Format. If "Q" is received on the serial port the scale will output the same as if the <i>PRINT/ENTER</i> key is pressed. The same holds true for: Z = ZERO U = lb/kg, D = GRS/NET T = TARE
		1	Slave Display output (numeric only) continuous Stx, Six ASCII Characters (indicated weight), CR, LF (9 Bytes total Output).
		2	Slave Display output (alphanumeric) continuous Stx, GR, NT, or TR, Six ASCII Characters (indicated weight), lb, kg, CR, LF (15 Bytes total output).
		3	RF Link Output.
		4	Used for QSI Terminal.

Press the right arrow key to enter. Use the numeric keypad to enter the desired selection (0 - 4), then press the *PRINT/ENTER* key to save and exit. R3 will be displayed.

4.1 Communications Menu Definitions Continued:

- R4 Receiver**
- 0** Disabled (Normal Scale Mode). (Default)
 - 1** Standard Receiver. Receives R3-3 RF Link output string displaying data as it appears on the scale. All keys are disabled with the exception of the *PRINT/ENTER* key. Pressing the *PRINT/ENTER* key will cause both COM1 and COM2 to print. If the print command is received from the scale COM1 the CSW-20 will print on both COM1 and COM2 (**if output type is set to print on command**).
 - 2** Remote control. Receives R3-3 RF Link output string displaying data as it appears on the scale and allows full control of all scale meter functions.
 - When pressing the *ZERO* KEY, COM1 will transmit the “Z” command to the scale.
 - When pressing the *GRS/NET* key, COM1 will transmit the “D” command to the scale.
 - When pressing the *lb/kg* key, COM1 will transmit the “U” command to the scale.
 - When pressing the *TARE* key, COM1 will transmit the “I” command to the scale.
 - When pressing the *PRINT/ENTER* key COM1 will transmit the “Q” command to the scale.
 - If the print command is received from the scale on COM1 the CSW-20 will print on COM2 (**if output type is set to print on command**).
- R5 Printer Format**
- While R5 is being displayed press 1, 2 or 3 to edit the 3 (30 character) header lines that will be printed at the top of each ticket. Press 1, r5 1 will be displayed, then 01 000 is displayed. This is the first character of line 1. Edit by using the numeric keypad to enter the 3 digit code for the character of choice (*Codes are shown in table 4.1 on the following page*). After entering the code, the display will advance to the next character to be edited. The left and right arrow keys can be used to go back and adjust codes that have been entered incorrectly. When the last code is entered, press *PRINT/ENTER* to save the data. The display will return to R5. Follow these steps to edit lines 2 and 3. A sample header, footer worksheet, and sample tickets are shown in figure 4.1 pages 20-22.

4.1 Communications Menu Definitions Continued:

If a line is cleared, no other line will be printed below it. An entire line can be cleared by entering the desired line and pressing the *ZERO* key then press the *PRINT/ENTER* key. The display will return to R5 and the line is cleared. While R5 is being displayed press 4 to edit the footer line That will be printed at the bottom of each ticket. Use the steps described above to edit this line. If this line is cleared nothing will be printed.

R6	Baud Rate COM2	0	1200
		1	2400
		2	4800
		3	9600 (Default)
		4	19200
		5	38400
		6	57600
		7	115200

Press the right arrow key to enter. Use the numeric keypad to enter the desired selection (0 - 7), then press the *PRINT/ENTER* key to save and exit. R6 will be displayed.

R7	Output Format COM2	0	Gross, Tare, Net (Default)
		1	Weight only
		2	Net only
		3	Gross only

Press the right arrow key to enter. Use the numeric keypad to enter the desired selection (0 - 3), then press the *PRINT/ENTER* key to save and exit. R7 will be displayed.

R8	Output Type COM2	0	Output on command. Standard Print. (Default) Output as selected by R2 Output Format. If “Q” is received on the serial port the scale will output the same as if the <i>PRINT/ENTER</i> key is pressed. The same holds true for Z = ZERO U = lb/kg, D = GRS/NET T = TARE
		1	Slave Display output (numeric only) continuous Stx, Six ASCII Characters (indicated weight), CR, LF (9 Bytes total Output).

- 2 Slave Display output (alphanumeric) continuous Stx, GR, NT, or TR, Six ASCII Characters (indicated weight), lb, kg, CR, LF (15 Bytes total output).
- 3 RF Link Output.
- 4 Used for QSI Terminal.
Press the right arrow key to enter. Use the numeric keypad to enter the desired selection (0 - 3), then press the *PRINT/ENTER* key to save and exit. R8 will be displayed.

R9 Time & Date

While R9 is being displayed press 1. r9 1 will be displayed, then the date. To change the date, use the numeric keypad to enter the Month first, then enter the day of the month, and Last enter the year. Then press *PRINT/ENTER*. The display Will return to r 9.

While R9 is being displayed press 2. r9 2 will be displayed, then the time. To change the time, use the numeric keypad, enter the hour first then enter the minutes (in 24 hr., format) and press *PRINT/ENTER*. The display will return to R9.

TABLE 4.1
Numeric Character Codes

LF	CR	(sp)	!	“	#	\$	%	&	‘	()	*
010	013	032	033	034	035	036	037	038	039	040	041	042
+	,	-	.	/	:	;	<	=	>	?	@	
043	044	045	046	047	058	059	060	061	062	063	064	

0	1	2	3	4	5	6	7	8	9
048	049	050	051	052	053	054	055	056	057

A	B	C	D	E	F	G	H	I	J	K	L	M
065	066	067	068	069	070	071	072	073	074	075	076	077
N	O	P	Q	R	S	T	U	V	W	X	Y	Z
078	079	080	081	082	083	084	085	086	087	088	089	090

a	b	c	d	e	f	g	h	i	j	k	l	m
097	098	099	100	101	102	103	104	105	106	107	108	109
n	o	p	q	r	s	t	u	v	w	x	y	z
110	111	112	113	114	115	116	117	118	119	120	121	122

Figure 4.1

4.1.a Completed Worksheet

Header message work sheet

01	02	03	04	05	06	07	08	09	10	11	12	13	14	15	16	17	18	19	20	21	22	23	24	25	26	27	28	29	30
067	097	109	098	114	105	100	103	101	032	083	099	097	108	101	032	087	111	114	107	115	032	073	110	099					
C	a	m	b	r	i	d	g	e	(sp)	S	c	a	l	e	(sp)	W	o	r	k	s	(sp)	I	n	c					

01	02	03	04	05	06	07	08	09	10	11	12	13	14	15	16	17	18	19	20	21	22	23	24	25	26	27	28	29	30
049	049	053	048	048	032	066	101	100	102	111	114	099	032	082	111	097	100	032	078	069									
1	1	5	0	0	(sp)	B	e	d	f	o	r	d	(sp)	R	o	a	d	(sp)	N	E									

01	02	03	04	05	06	07	08	09	10	11	12	13	14	15	16	17	18	19	20	21	22	23	24	25	26	27	28	29	30
067	117	109	098	101	114	108	097	110	100	032	077	068	032	050	049	053	048	050											
C	u	m	b	e	r	l	a	n	d	(sp)	M	D	(sp)	2	1	5	0	2											

Footer message work sheet

01	02	03	04	05	06	07	08	09	10	11	12	13	14	15	16	17	18	19	20	21	22	23	24	25	26	27	28	29	30
084	104	105	115	032	073	115	032	065	032	051	048	032	067	104	097	114	097	067	116	101	114	032	070	111	111	116	101	114	
T	h	i	s	(sp)	I	s	(sp)	A	(sp)	3	0	(sp)	C	h	a	r	a	c	t	e	r	(sp)	F	o	o	t	e	r	

4.1.b Blank Worksheet

Header message work sheet

01	02	03	04	05	06	07	08	09	10	11	12	13	14	15	16	17	18	19	20	21	22	23	24	25	26	27	28	29	30	

01	02	03	04	05	06	07	08	09	10	11	12	13	14	15	16	17	18	19	20	21	22	23	24	25	26	27	28	29	30	

01	02	03	04	05	06	07	08	09	10	11	12	13	14	15	16	17	18	19	20	21	22	23	24	25	26	27	28	29	30	

Footer message work sheet

01	02	03	04	05	06	07	08	09	10	11	12	13	14	15	16	17	18	19	20	21	22	23	24	25	26	27	28	29	30	

Figure 4.1.c Sample Ticket

Cambridge Scale Works Inc
113 West Mary Street
Cumberland MD 21502
3:45 pm 05/15/2007

Id# 1234567890

Gross(lb): 1200
Tare(lb): 200
Net(lb): 1000

Avg Pc Wt(lb) .500000
Pieces 2000

Weigh From Scale S/N: 07-12730

Figure 4.1.d Sample Ticket

Cambridge Scale Works Inc
113 West Mary Street
Cumberland MD 21502
3:45 pm 05/15/2007

Wt# 1 550
Wt# 2 450
Total wt. 1000 lb

Avg Pc Wt(lb) .500000
Pieces 2000

If the average piece weight is 0 then the Average Piece weight and Pieces will not be printed on the tickets.

5.0 TESTING PROCEDURES

5.1 Testing Menu Definitions:

T1	Software Version	Displays the software version. Press <i>PRINT/ENTER</i> to exit.
T2	Display	Flashes all display segments then all indicating Enunciators. Press PRINT/ENTER to exit.
T3	Keys	Press each key to display the row and column of that key. Press the <i>PRINT/ENTER</i> to exit.
T4	A to D	Displays Raw counts where a 1mV/V signal from the scale will display 25,000 counts. When the indicator is in angle mode, Press the <i>GRS/NET</i> key to cycle Pitch, Roll and Raw counts. Press the <i>PRINT/ENTER</i> Key to exit.
T5	Serial COM1	Serial Communications can be verified by connecting pins 2 and 3 on the serial port. A single character will be echoed and pass or fail will be displayed. Press the <i>PRINT/ENTER</i> key to exit.
T6	Setup Data	Setup data will be sent out on the printer port.
T7	Default	Resets the indicator back to the factory settings. This will clear all calibration and setup data. “r you sure?” will be displayed. Press the <i>TARE</i> key to exit without Defaulting, or press the <i>PRINT/ENTER</i> key to reset the indicator to the factory default settings.
T8	Serial COM2	Serial Communications can be verified by connecting pins 2 and 3 on the serial port. A single character will be echoed and pass or fail will be displayed. Press the <i>PRINT/ENTER</i> key to exit.

6.0 Troubleshooting Guide

Error Message Or Problem	Description	Possible Solution
Err d		<ul style="list-style-type: none"> - More than 5000 scale divisions have been selected in Nstep or Angle Mode. - Zeroing a weight larger than scale capacity.
oLd	The scale is in an over load condition.	<ul style="list-style-type: none"> - Check signal / load cell cable for damage or loose connections
SCnEg	The Scales weight is more than 10 divisions negative from the zero calibration point in Nstep or Angle mode.	<ul style="list-style-type: none"> -Check for any debris interfering with the scale structure. -Check signal/load cell cable for damage or loose connections. -Re establish “C2” the zero calibration point.
AngErr	Data communications from the angle sensor has been lost.	<ul style="list-style-type: none"> -Check signal/Load cell cable for damage or loose connections. -If the scale system is not a CSW-10-LFT, change “S1” Parameter to the Nstep or no setting.
Bat Lo	Flashes when the battery voltage falls to 10.8V, and will be displayed contently when the voltage falls below 10.2V.	<ul style="list-style-type: none"> -Verify the battery is fully charged. -Check cables for any damages. -Check the power connections. They should be clean and tight.
No Display		<ul style="list-style-type: none"> -Disconnect all cables except for power, and then turn the indicator on. If the display lights up, inspect all cables. -Check the AC adapters output. -Check for an open fuse or low battery on DC powered systems. -Verify that all power connections are clean and tight.
Weight Readings Are Incorrect.		<ul style="list-style-type: none"> -Check for any Debris interfering with the scale structure. -Check the signal/load cell cable for damage or loose connections. -Verify that each load cell responds equally to an applied weight. -Recalibrate system with a known weight.

6.0 Troubleshooting Guide

Error Message Or Problem	Description	Possible Solution
Weights will not Repeat.		<ul style="list-style-type: none"> -Check for any Debris interfering with the scale structure. -Verify that each load cell responds equally to an applied weight.
Unstable Readings		<ul style="list-style-type: none"> -Check signal / load cell cable for damage or loose connections -Check for any Debris interfering with the scale structure. -Make sure the Junction Box and cable connections are clean and dry. -Check for a loose or bad load cell connection. -If the system has been recalibrated, Verify that the displayed weight is not greater than 200 percent of the known weight. -Check for a load cell problem. Connect 1 load cell at a time to find the unstable cell.
Wireless Keypad will not respond.		<ul style="list-style-type: none"> -Check the battery in the wireless keypad -Check for the antenna on the scale to be installed and undamaged. -Check that the switch settings on the wireless keypad match the switch settings on the scale indicator PC board.

7.0 WARRANTY

CAMBRIDGE warrants the **CSW-20** to be free of defects in workmanship and/or materials for 12 months from the date of shipment. This warranty of workmanship and/or materials, is valid, if in the opinion of **CAMBRIDGE**, the equipment has not been mechanically, environmentally, or electrically abused.

This warranty is limited, at the option of **CAMBRIDGE**, to repair, replace or an appropriate credit adjustment not to exceed the original equipment sale price paid to **CAMBRIDGE**. **CAMBRIDGE** assumes no liability in connection with the sales of its products beyond that stated above.

Warranty replacement parts and/or repair services are performed at the factory in Cumberland, Maryland or by an authorized Service Group approved by **CAMBRIDGE**.

Warranty does not include travel expense if a factory technician is requested to perform repairs at a location other than the factory.

It is the user's responsibility to follow the proper set-up, calibration and operating procedures of the **CSW-20** as described in this manual. If the operator has difficulty using their **CSW-20** indicator properly, please contact **CAMBRIDGE** at 1-301-724-4082. Any one of our Technicians will be happy to work with the user via telephone.

Thank You!

8.0 ASSISTANCE:

If at any time and you require assistance with your **CSW-20** Indicator:

End User please contact your servicing scale dealer.

Authorized Cambridge Dealer/ Distributor please contact:

CAMBRIDGE SCALE WORKS, INC.

115 West Mary Street
Cumberland, MD 21502

Phone: (301) 724-4082
Fax: (301) 724-4964